

AXIAL WAREHOUSE EXHAUST FAN  
 ARRANGEMENT 4, LEVEL 2, VERTICAL DISCHARGE, BASE MOUNT

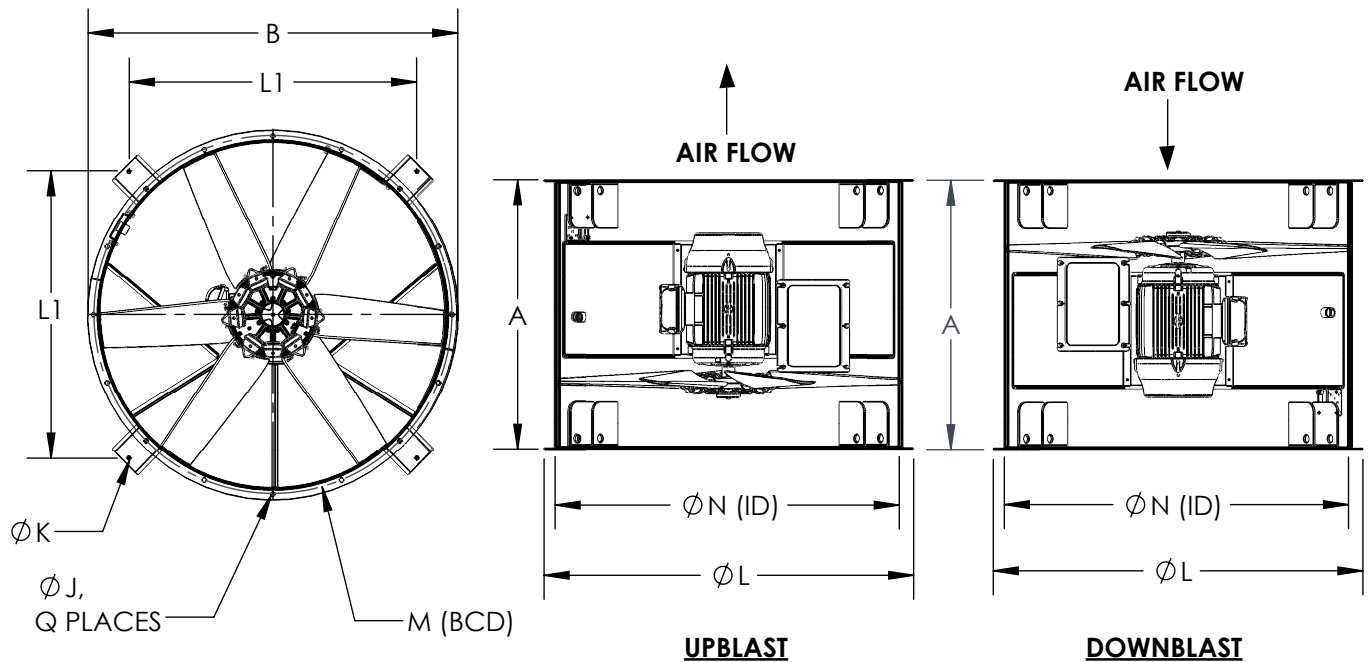

**STANDARD CONSTRUCTION:**

1. High efficiency adjustable pitch, cast aluminum airfoil propeller (06 or 09 blades)
2. Bolted access door
3. Bolted switch bracket
4. Air dry enamel coating

**ACCESSORIES**

1. NEMA 3R service switch
2. Mounting rails
3. Vibration isolators
4. Extended lubrication lines (PVC or copper)
5. Drain
6. Companion flange
7. Inlet bell
8. Inlet/outlet guard
9. VFD

**DIMENSIONAL DATA:**

SIZE	A	B	J	K	L	M	N	Q	L1	MIN. MTR FRAME	MAX. MTR FRAME	UNIT WEIGHT (LESS MOTOR)
AWX-1600	49 1/8	67 3/8	13/16	13/16	67 3/8	65 1/4	63	16	52 3/8	256T	326T	975

ALL DIMENSIONS ARE INCHES AND WEIGHTS IN LBS.